



MAX7359 Evaluation Kit

General Description

The MAX7359 evaluation kit (EV kit) is an assembled and tested printed-circuit board (PCB) that demonstrates the MAX7359 2-wire interfaced low-EMI key switch controller. Windows® 2000/XP/Vista-compatible software provides a handy user interface to exercise the features of the MAX7359.

Features

- ◆ Windows 2000/XP/Vista (32-Bit)-Compatible Software
- ◆ Proven PCB Layout
- ◆ Complete Evaluation System
- ◆ 8 x 8 Key Matrix Included
- ◆ Optional PORT2–PORT7 Output LEDs
- ◆ Fully Assembled and Tested

Ordering Information

PART	TYPE
MAX7359EVKIT+	EV kit

+Denotes lead-free and RoHS-compliant.

Component List

DESIGNATION	QTY	DESCRIPTION
C1, C5–C9, C17, C18, C37	9	0.1µF ±10%, 10V (min) X7R ceramic capacitors (0603) TDK C1608X7R1C104K Taiyo Yuden EMK107BJ104KA Murata GRM188R71C104K
C2	0	Not installed, capacitor (0603)
C4	1	0.033µF ±10%, 6.3V (min) X7R ceramic capacitor (0603) TDK C1608X7R1E333K Murata GRM188R71E333K Taiyo Yuden EMK107BJ333KA
C10, C39	2	1µF ±10%, 16V X5R ceramic capacitors (0603) TDK C1608X5R1C105K Murata GRM188R61C105K AVX 0603YD105MAT KEMET C0603C105K4PAC
C11, C12, C38, C40	4	10µF ±20%, 16V X5R ceramic capacitors (1206) Murata GRM31CR61C106M TDK C3216X5R1C106M Panasonic ECJ3YB1C106M KEMET C1206C106M4PAC
C15, C16	2	10pF ±5%, 50V C0G ceramic capacitors (0603) Murata GRM1885C1H100J TDK C1608C0G1H100J Taiyo Yuden UMK107CG100DZ

DESIGNATION	QTY	DESCRIPTION
C30, C31	2	22pF ±5%, 50V C0G ceramic capacitors (0603) Murata GRM1885C1H220J TDK C1608C0G1H220J Taiyo Yuden UMK107CG220KZ
H1–H4	4	6-pin headers
J1	1	USB series type-B right-angle PC-mount receptacle
J3 (JTAG)	1	Vertical header, 2 x 5 pins (keyed pin 7)
JU1	1	Dual-row vertical header, 2 x 4 pins
JU2	1	3-pin header
JU3–JU8	6	2-pin headers
JU9–JU13	0	Not installed, 2-pin headers—PCB shorted trace
KEY0–KEY63	64	Momentary 6mm pushbutton switches OMRON B3F1000
L1	1	Ferrite bead (0603) TDK MMZ1608R301A Murata BLM18SG700 TN1
LED1–LED8	8	Red LEDs (T1-3/4)
R1, R2	2	27Ω ±5% resistors (0603)
R3, R7, R8	3	1.5kΩ ±5% resistors (0603)
R4	1	470Ω ±5% resistor (0603)
R5	1	2.2kΩ ±5% resistor (0603)

Windows is a registered trademark of Microsoft Corp.



MAX7359 Evaluation Kit

Component List (continued)

DESIGNATION	QTY	DESCRIPTION
R6	1	10k Ω \pm 5% resistor (0603)
R9	1	33k Ω \pm 5% resistor (0603)
R10–R17	8	330 Ω \pm 5% resistors (0603)
R18	1	0 Ω resistor (0603)
R19–R23	0	Not installed, resistors—PCB shorted trace (0402)
U1	1	Maxim I ² C interfaced peripheral MAX7359ETG+ (24-pin TQFN-EP, 3.5mm x 3.5mm)
U2	1	Maxim LDO linear regulator MAX8511EXK25+ (5-pin SC70) (Top Mark: ADV)
U3	1	Maxim LDO linear regulator MAX8511EXK33+ (5-pin SC70) (Top Mark: AEI)
U4	1	Maxim RISC microcontroller MAXQ2000-RAX+ (68-pin QFN)

DESIGNATION	QTY	DESCRIPTION
U5	1	FTDI FT232BL (32-pin TQFP, 7mm x 7mm)
U6	1	93C46 type 3-wire EEPROM (8-pin SO)
Y2	1	16MHz crystal (parallel resonant, 20pF load) Citizen HCM49-16.000MABJUT Suntsu SCD20B-16.000MHZ-I
Y3	0	Not installed, 32.768kHz watch crystal
Y4	1	6MHz crystal
—	8	Shunts
—	1	PCB: MAX7359 Evaluation Kit+
—	4	Rubber bumpers, 0.100in H x 0.400in W square
—	1	USB high-speed A-to-B cable, 5ft (1.5m)

Component Suppliers

SUPPLIER	PHONE	WEBSITE
Murata Mfg. Co., Ltd.	770-436-1300	www.murata.com
Panasonic Corp.	714-373-7366	www.panasonic.com
Taiyo Yuden	800-348-2496	www.t-yuden.com
TDK Corp.	847-803-6100	www.component.tdk.com

Note: Indicate that you are using the MAX7359 when contacting these component suppliers.

MAX7359 Evaluation Kit

Evaluates: MAX7359

Quick Start

Required Equipment

Before beginning, the following equipment is needed:

- User-supplied Windows 2000/XP/Vista-compatible computer with a spare USB port

Note: Administrator privileges may be required when first installing the device.

Note: In the following sections, software-related items are identified by bolding. Text in **bold** refers to items directly from the EV kit software. Text in **bold and underlined** refers to items from the Windows operating system.

Procedure

The MAX7359 EV kit is fully assembled and tested. Follow the steps below to verify board operation.

- 1) Visit www.maxim-ic.com/evkitsoftware to download the latest version of the EV kit software, 7359Rxx.ZIP. Save the EV kit software to a temporary folder and uncompress the ZIP file.
- 2) Install the EV kit software on your computer by launching the 7359Rxx.MSI program inside the zip file. The program files are copied and icons are created in the Windows **Start | Programs** menu.
- 3) Ensure that the jumper settings are in the default positions (see Table 1).
- 4) Connect the USB cable from the PC to the MAX7359 EV kit board. A **Building Driver Database** window pops up in addition to a **New Hardware Found** message when installing the USB driver for the first time. If you do not see a window that is similar to the one described above after 30s, remove the USB cable from the board and reconnect it. Administrator privileges are required to install the USB device driver on Windows 2000 and XP. Refer to *Application Note 3601: Troubleshooting Windows Plug-and-Play and USB for Maxim Evaluation Kits* if you have any problems during this step.

- 5) Follow the directions of the **Add New Hardware Wizard** to install the USB device driver. Choose the **Search for the best driver for your device** option. Specify the location of the device driver to be **C:\Program Files\Maxim MAX7359EVKIT** (default installation directory) using the **Browse** button. During device driver installation, Windows XP shows a warning message indicating that the device driver Maxim uses does not contain a digital signature. This is not an error condition. It is safe to proceed with the installation.
- 6) Verify that the EV kit's LED8 is lit, indicating that the USB is connected and providing power.
- 7) Start the EV kit software by clicking its icon in the Windows **Start** menu.
- 8) The software automatically connects to the board after a few seconds.
- 9) Click the **Initialize EV kit** button to write the power-up command and configure default settings for demonstration. This button writes to three registers: Write(0x01 Configuration) = 0xAA; Write(0x02 Debounce) = 0x1F; and Write(0x03 Interrupt) = 0x2F.
- 10) On the EV kit board, press buttons in the KEY0–KEY63 matrix. Verify that the key scan codes are reported in the software's history window after five to six key-press events are queued, depending on the debounce time and interrupt register settings. The most recent scan code is identified in the **Key Grid**.

Detailed Description of Software

Connecting to Hardware

The MAX7359 EV kit software main window (Figure 1) provides direct access to all registers and controls the interrupt response. The software automatically searches for the MAX7359 EV kit hardware when launched. Once the hardware is found and connected, the **I²C Device Address** is shown in the upper-left corner.

Auto Read

The software automatically reads registers every 2s to 3s if the **Auto Read all** checkbox is checked.

MAX7359 Evaluation Kit

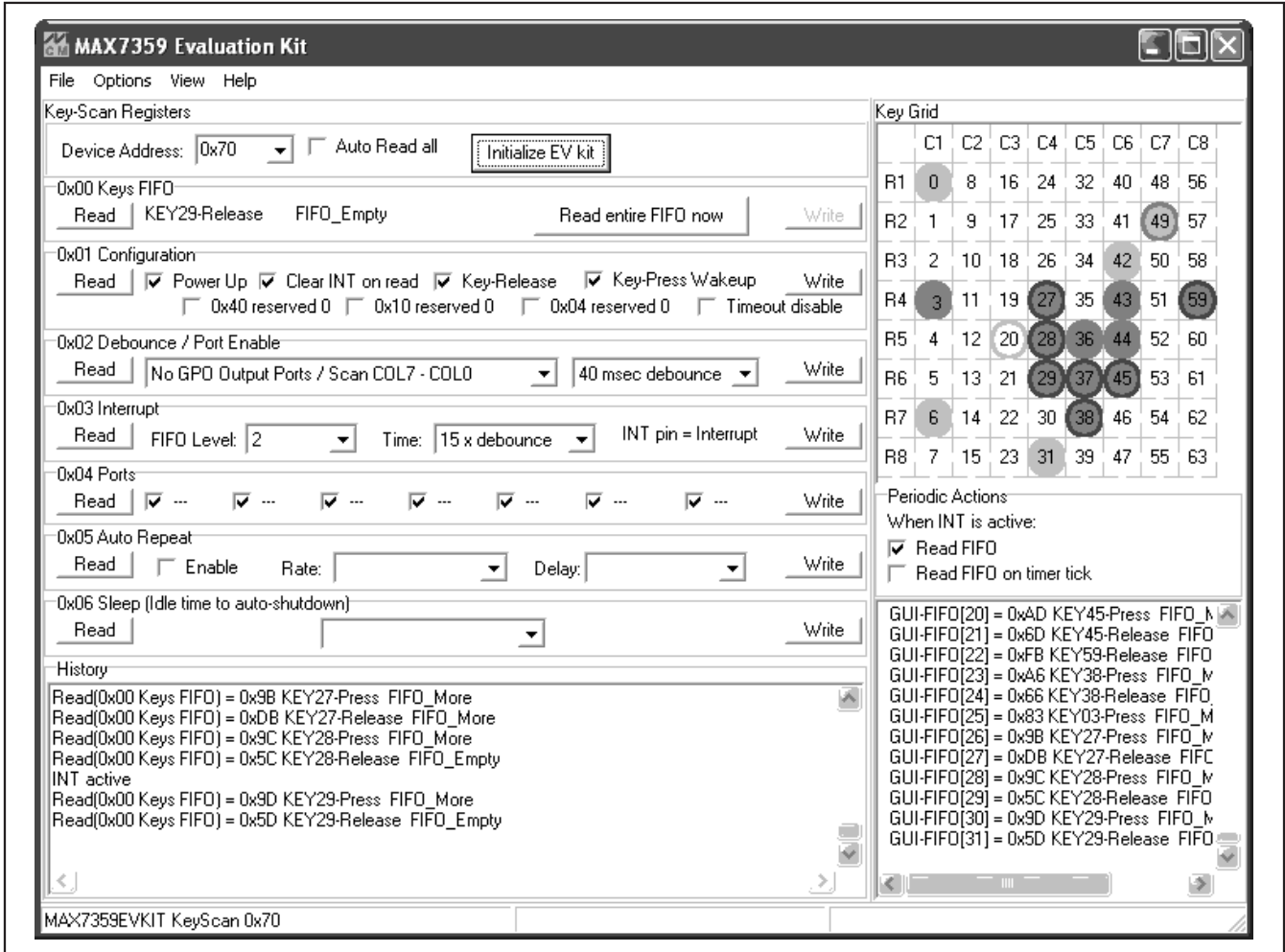

Figure 1. The MAX7359 EV Kit Software Main Window

Registers

Each of the MAX7359 registers is represented on the software's main window (Figure 1). Each register has its own **Read** and **Write** buttons. Clicking the **Read entire FIFO now** button reads register 0x00 repeatedly, until the FIFO indicates that all key-press events have been read.

Key Grid

Whenever a key-press event is received, the key location is shown on the **Key Grid**. This grid shows eight rows and eight columns. Register **0x02 Debounce / Port Enable** determines how many of the column pins are taken away from the **Key Grid** and used for general-purpose outputs (GPOs).

Interrupt Response

Although the PC software cannot respond to interrupts with the speed of a true low-level hardware interrupt, the software does offer flexibility for evaluation. The software polls the status of the INT output pin twice every second. The **Periodic Actions** checkboxes determine what action the software will take when INT is active.

History Window

Each register read or write event is recorded in the scrollable **History** window.

MAX7359 Evaluation Kit

Evaluates: MAX7359

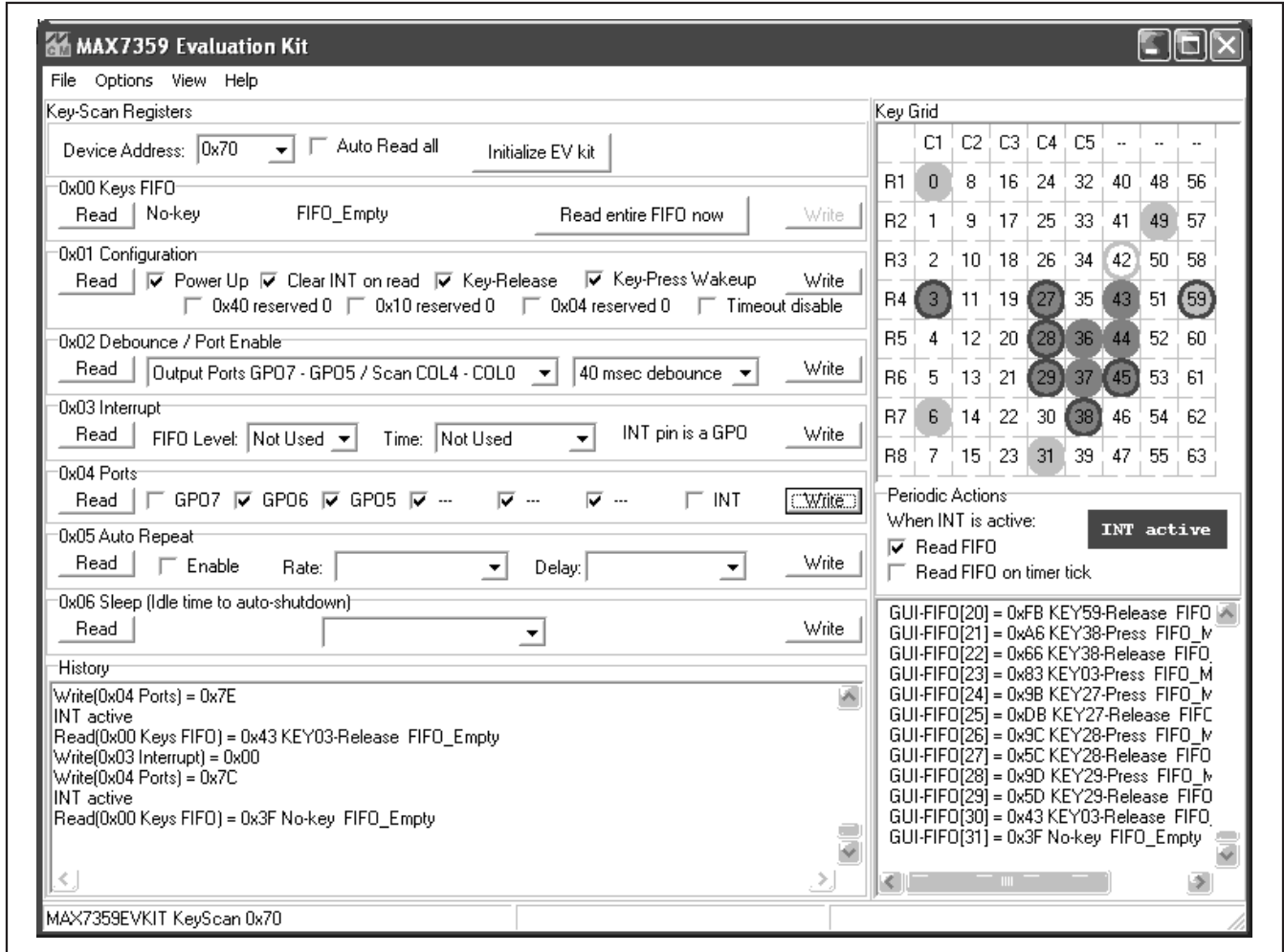

Figure 2. Using the LEDs as GPO Indicators

Using the LEDs as GPO Indicators

To configure the COL7/PORT7 pin as an open-drain GPO, first change the key scan partition by changing the value of the **0x02 Debounce / Port Enable** register to **Output Ports GPO7 / Scan COL6 - COL0**. Next, click its **Write** button. Finally, connect LED7 to the COL7/PORT7 pin by installing a shunt at JU8. To drive PORT7 low, illuminating the LED, set the value of the **0x04 Ports** register so that the **GPO7** checkbox is unchecked, and click its **Write** button (Figure 2).

To configure additional COL/PORT pins as open-drain GPOs, the procedure is similar. Write the **0x02 Debounce / Port Enable** register to select how many of

the COL/PORT pins will be used for key scanning and how many for output ports. Key scanning always uses the lowest numbered COL/PORT pins. Set the JU3–JU8 jumpers to enable the LED outputs as needed. Write the port data into the **0x04 Ports** register (unchecked = output low, checked = output undriven). Refer to the MAX7359 IC data sheet for more information about the ports register.

To configure the INT pin for use as a GPO pin, set both the **FIFO Level** and **Time** combo box of register **0x03 Interrupt** to **Not Used**, then click the **Write** button. When configured for GPO, the INT pin is controlled from the **0x04 Ports** register (Figure 2).

MAX7359 Evaluation Kit

Detailed Description of Hardware

The MAX7359 (U1) scans a matrix of keys (KEY0–KEY63). The EV kit provides an 8 x 8 matrix of keys. To demonstrate GPO capability, LED indicators are jumper-selectable for COL2/PORT2–COL7/PORT7.

The FTDI FT232BL (U5) provides the USB engine. The USB 5V power is regulated down to 2.5V by U2. LED8 indicates that USB 5V power is present.

Jumpers JU10 and JU11 optionally disconnect the MAX7359 SCL/SDA, allowing the use of an external user-provided I²C bus. Jumpers JU12 and JU13 optionally disable the on-board 1.5k Ω termination resistors (R7 and R8), allowing the use of external user-provided I²C pullup resistors.

The low-voltage RISC microcontroller, MAXQ2000 (U4), processes commands sent by a program running on the PC. Each particular EV kit has its own custom software specific to that kit. The firmware loaded on this board is identical to the MINIQUSB interface module.

Using an External I²C Bus Instead of USB

To disconnect from the on-board I²C bus, cut the links at jumper locations JU10 and JU11. If the external I²C bus already has appropriate pullup resistors, cut the links at jumper locations JU12 and JU13. Leave the USB connector (J1) unconnected. Move the JU2 shunt to pins 2-3, and provide 2.5V to 3.6V power to the GND and EXT V+ oval pads. Connect the external I²C bus to the SCL and SDA test points of header H3.

Table 1. Jumper Functions

JUMPER	SIGNAL	SHUNT POSITION	EXPLANATION
JU1	AD0	1-2*	AD0 = GND; I ² C address 0x70 / 0x72
		3-4	AD0 = SCL; I ² C address 0x7C / 0x7E
		5-6	AD0 = V _{CC} ; I ² C address 0x74 / 0x76
		7-8	AD0 = SDA; I ² C address 0x78 / 0x7A
JU2	VCC	1-2	U1 V _{CC} = V _{DDIO} (3.3V)
		2-3	U1 V _{CC} = external user-provided power
JU3	COL2/PORT2	1 only*	Use COL2 for key scan
		1-2	Use PORT2 to drive LED2
JU4	COL3/PORT3	1 only*	Use COL3 for key scan
		1-2	Use PORT3 to drive LED3
JU5	COL4/PORT4	1 only*	Use COL4 for key scan
		1 and 2	Use PORT4 to drive LED4
JU6	COL5/PORT5	1 only*	Use COL5 for key scan
		1 and 2	Use PORT5 to drive LED5
JU7	COL6/PORT6	1 only*	Use COL6 for key scan
		1 and 2	Use PORT6 to drive LED6
JU8	COL7/PORT7	1 only*	Use COL7 for key scan
		1 and 2	Use PORT7 to drive LED7
JU9	$\overline{\text{INT}}$	Not installed*	$\overline{\text{INT}}$ connected to MAXQ2000
		PCB trace cut open	$\overline{\text{INT}}$ connected to user-supplied microcontroller
JU10	SDA	Not installed*	SDA connected to on-board I ² C bus
		PCB trace cut open	SDA must be connected to an external I ² C bus
JU11	SCL	Not installed*	SCL connected to on-board I ² C bus
		PCB trace cut open	SCL must be connected to an external I ² C bus
JU12	SDA	Not installed*	SDA connected to on-board pullup resistor
		PCB trace cut open	SDA pullup resistor must be provided externally
JU13	SCL	Not installed*	SCL connected to on-board pullup resistor
		PCB trace cut open	SCL pullup resistor must be provided externally

*Default position.

MAX7359 Evaluation Kit

Evaluates: MAX7359

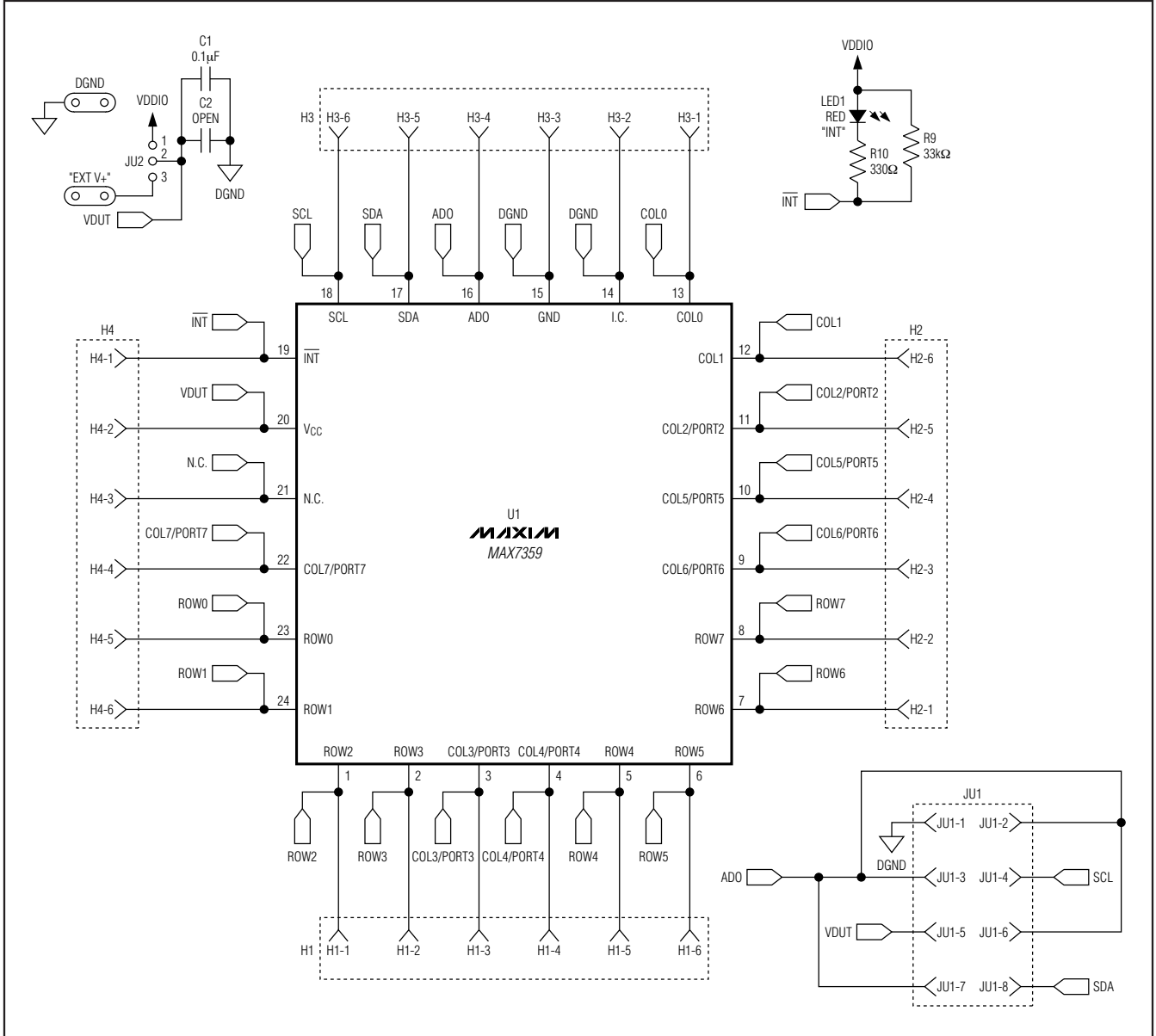

Figure 3a. MAX7359 EV Kit Schematic (Sheet 1 of 5)

MAX7359 Evaluation Kit

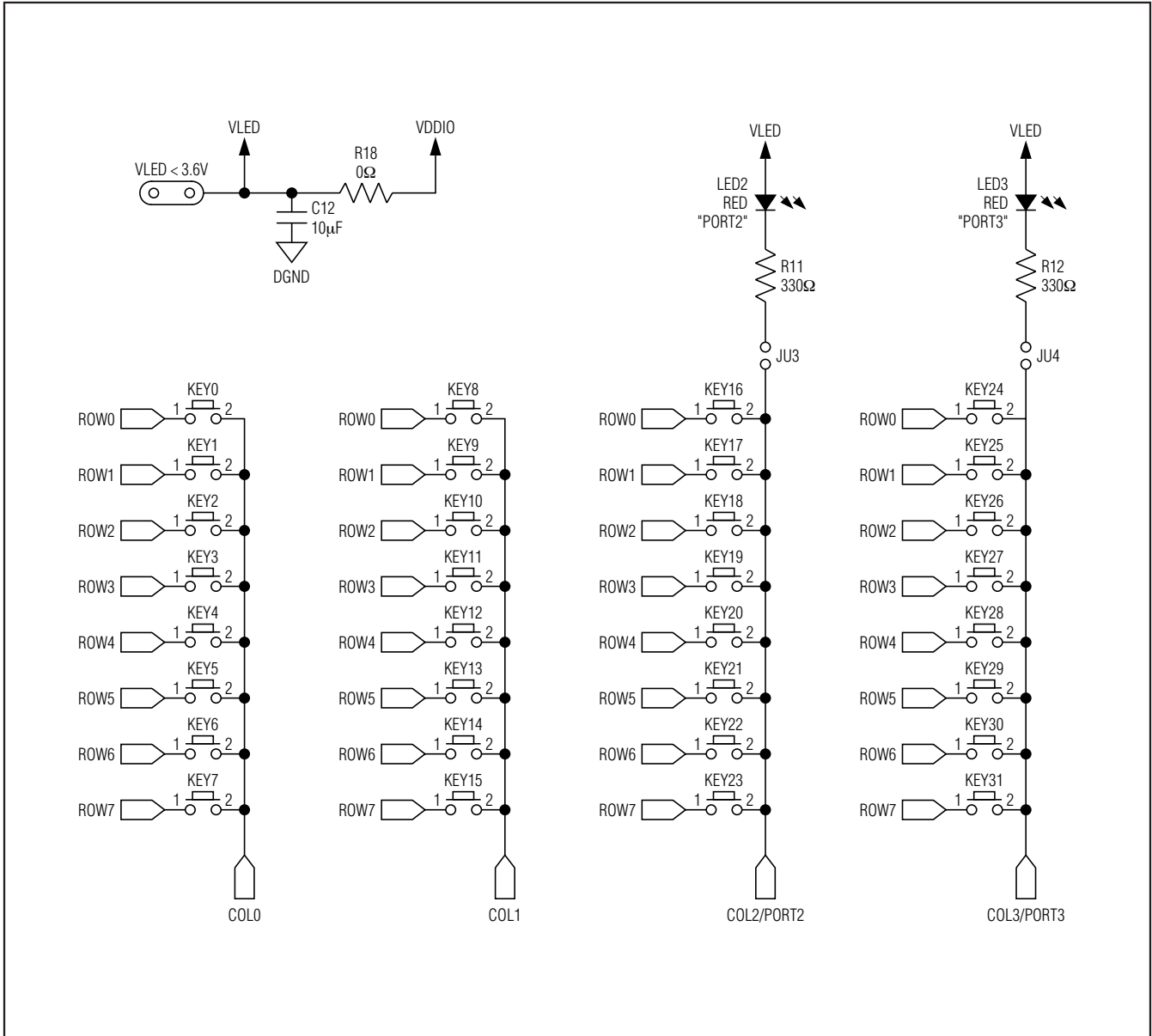

Figure 3b. MAX7359 EV Kit Schematic (Sheet 2 of 5)

MAX7359 Evaluation Kit

Evaluates: MAX7359

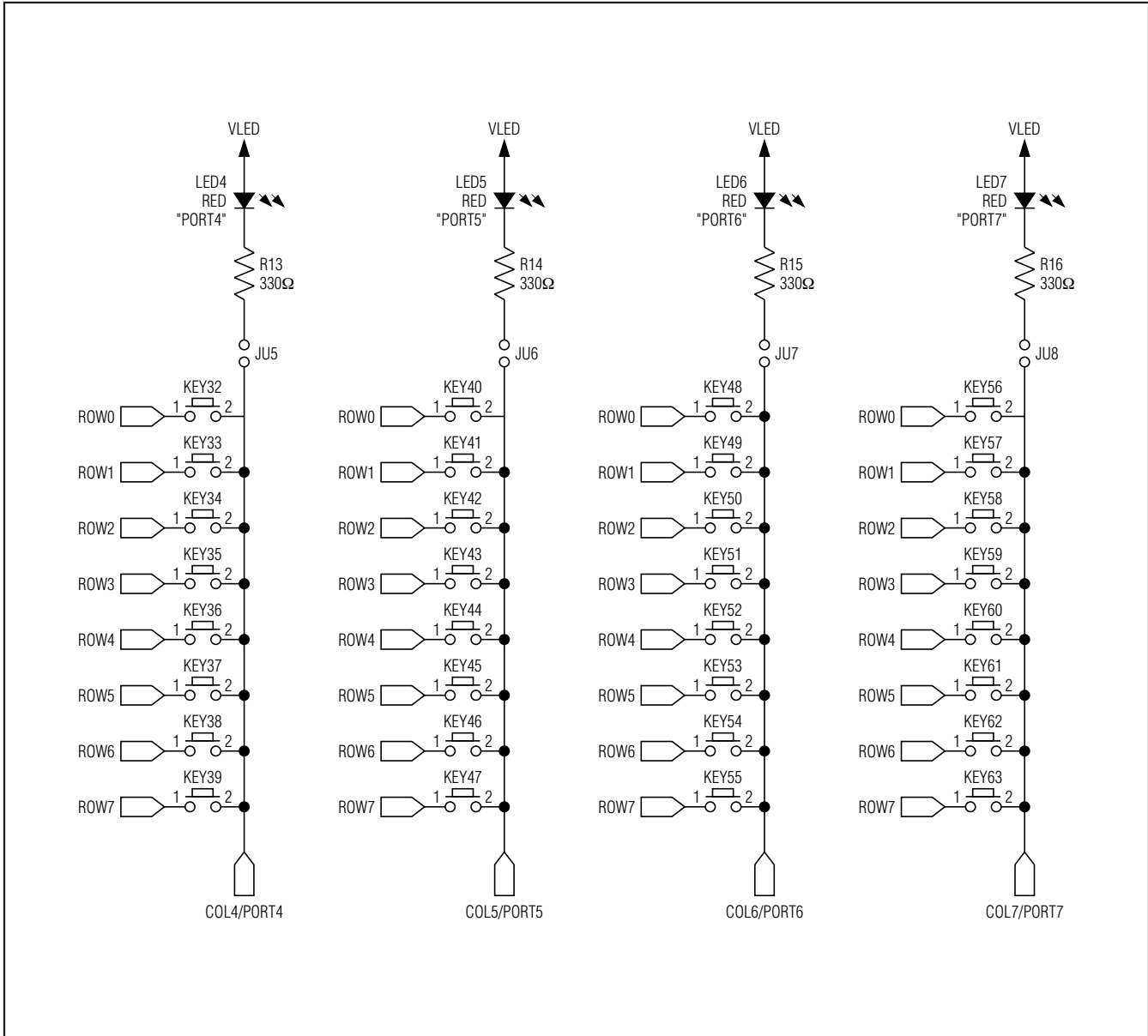

Figure 3c. MAX7359 EV Kit Schematic (Sheet 3 of 5)

MAX7359 Evaluation Kit

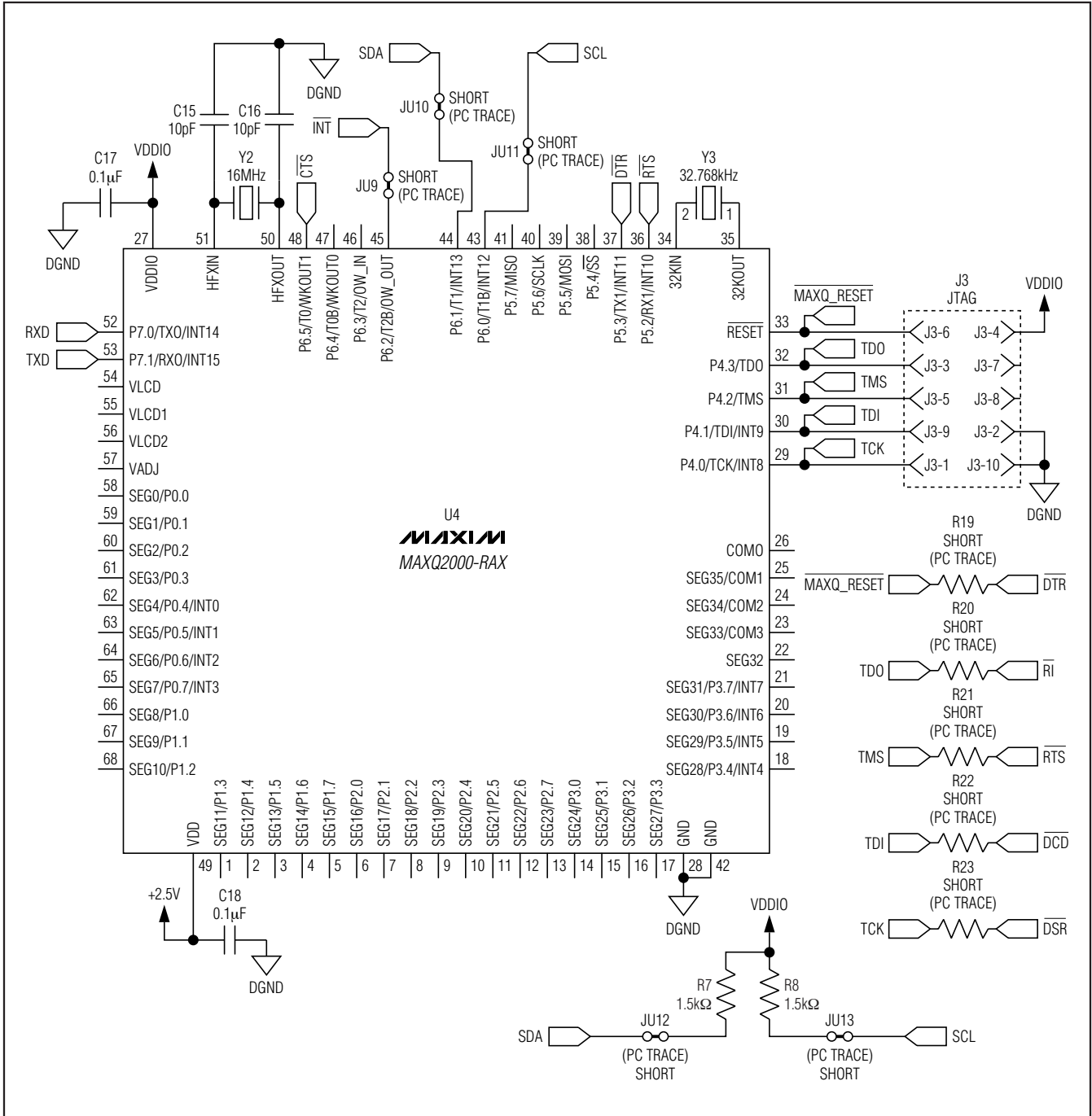

Figure 3d. MAX7359 EV Kit Schematic (Sheet 4 of 5)

MAX7359 Evaluation Kit

Evaluates: MAX7359

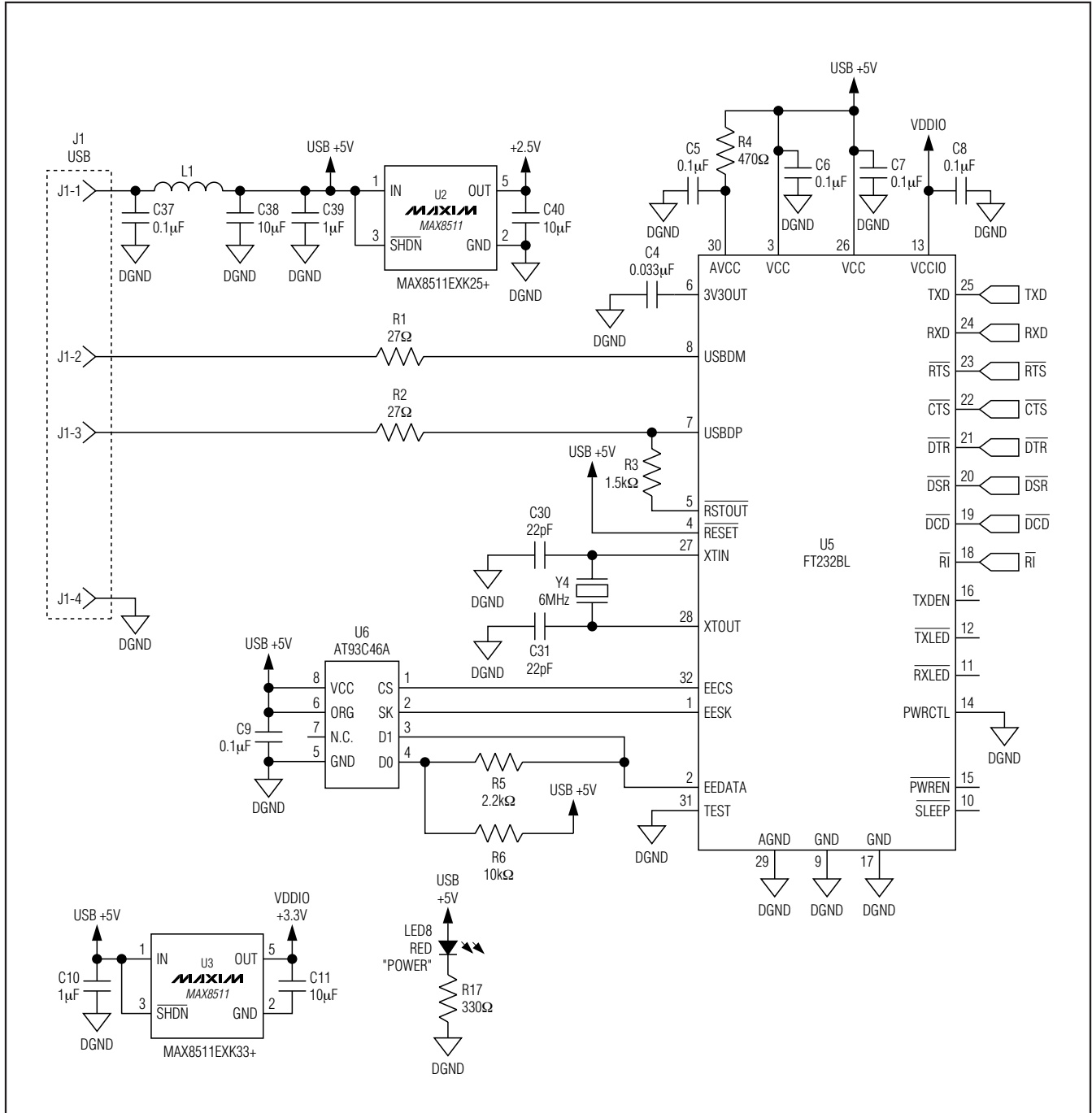

Figure 3e. MAX7359 EV Kit Schematic (Sheet 5 of 5)

MAX7359 Evaluation Kit

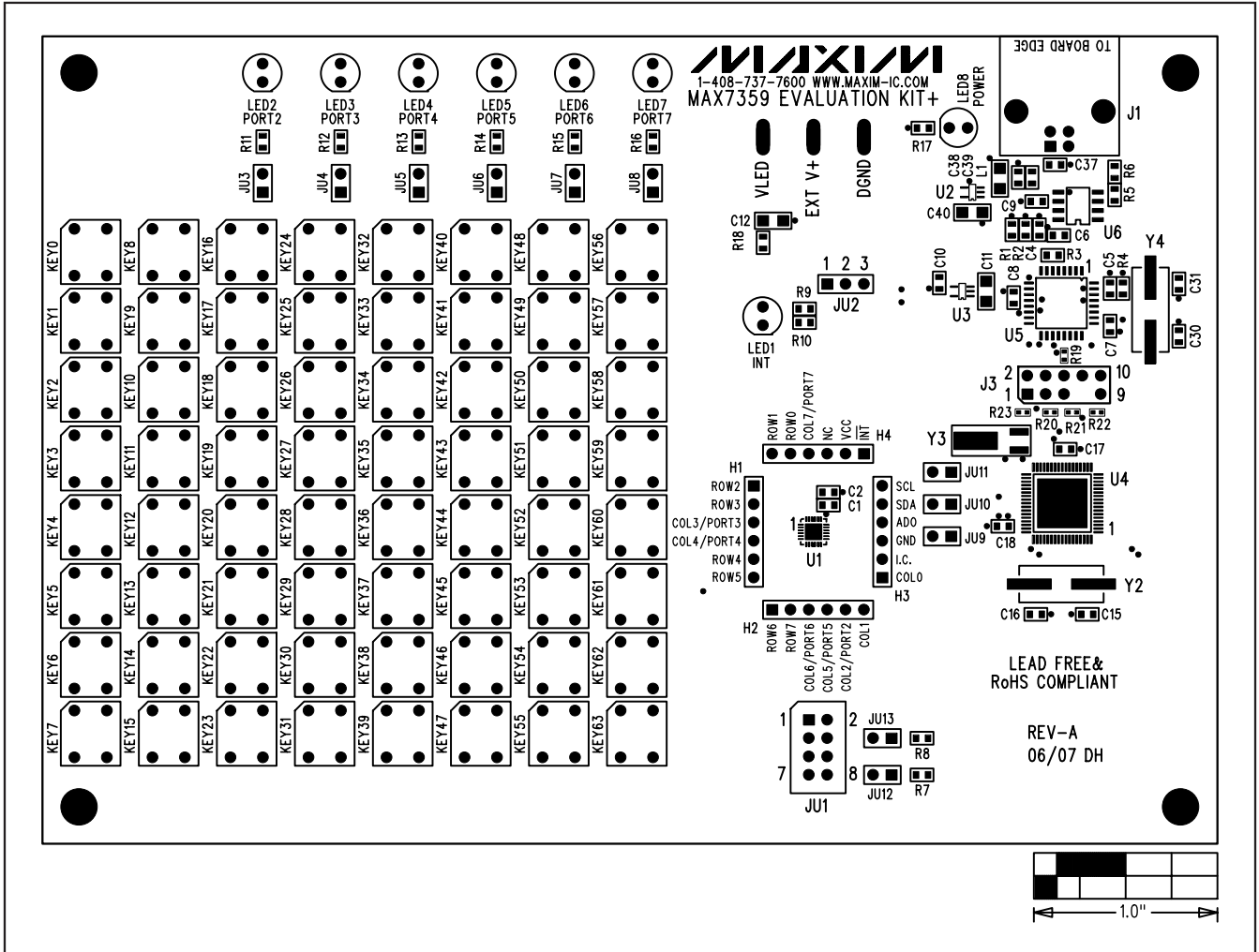

Figure 4. MAX7359 EV Kit Component Placement Guide—Component Side

MAX7359 Evaluation Kit

Evaluates: MAX7359

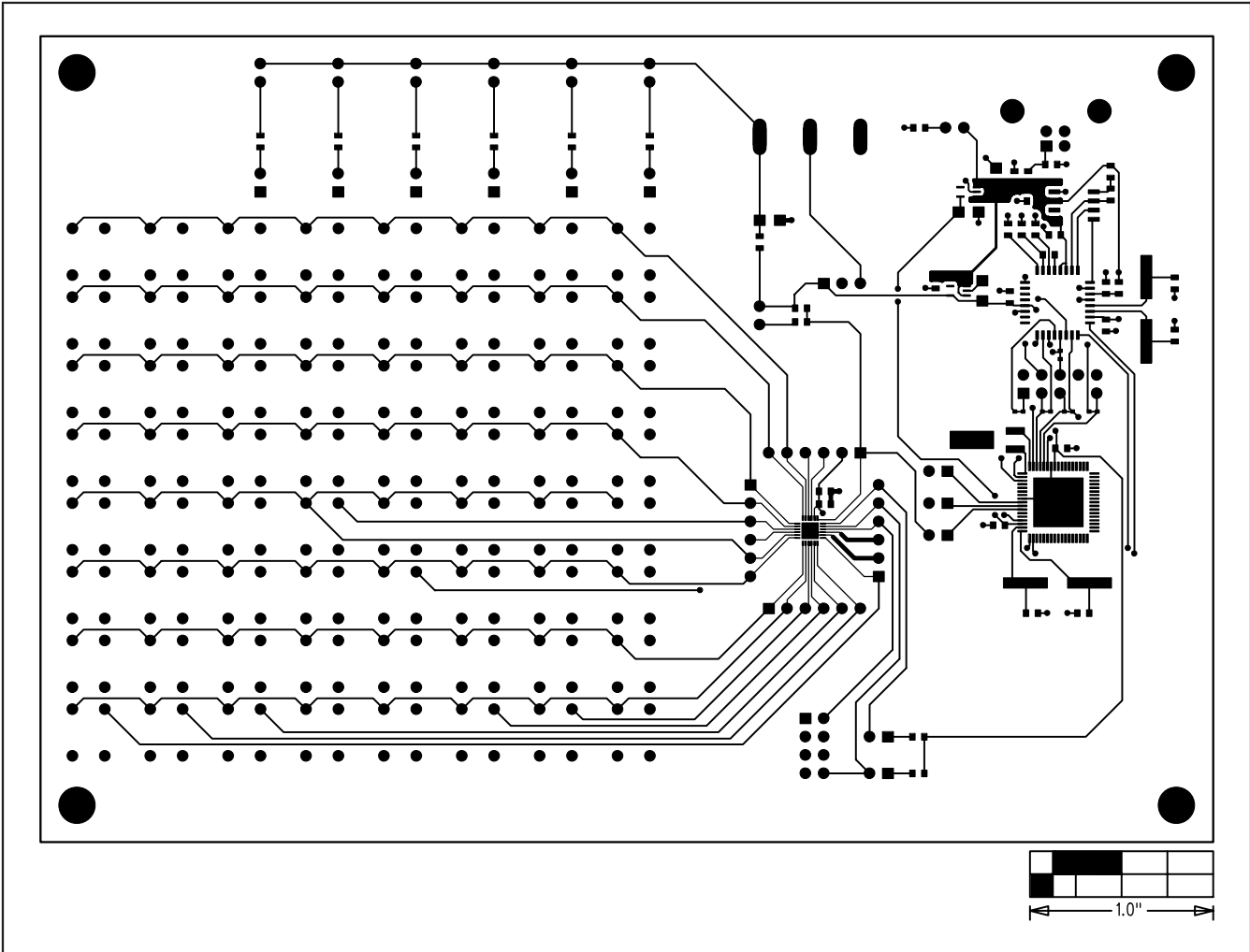

Figure 5. MAX7359 EV Kit PCB Layout—Component Side

MAX7359 Evaluation Kit

Evaluates: MAX7359

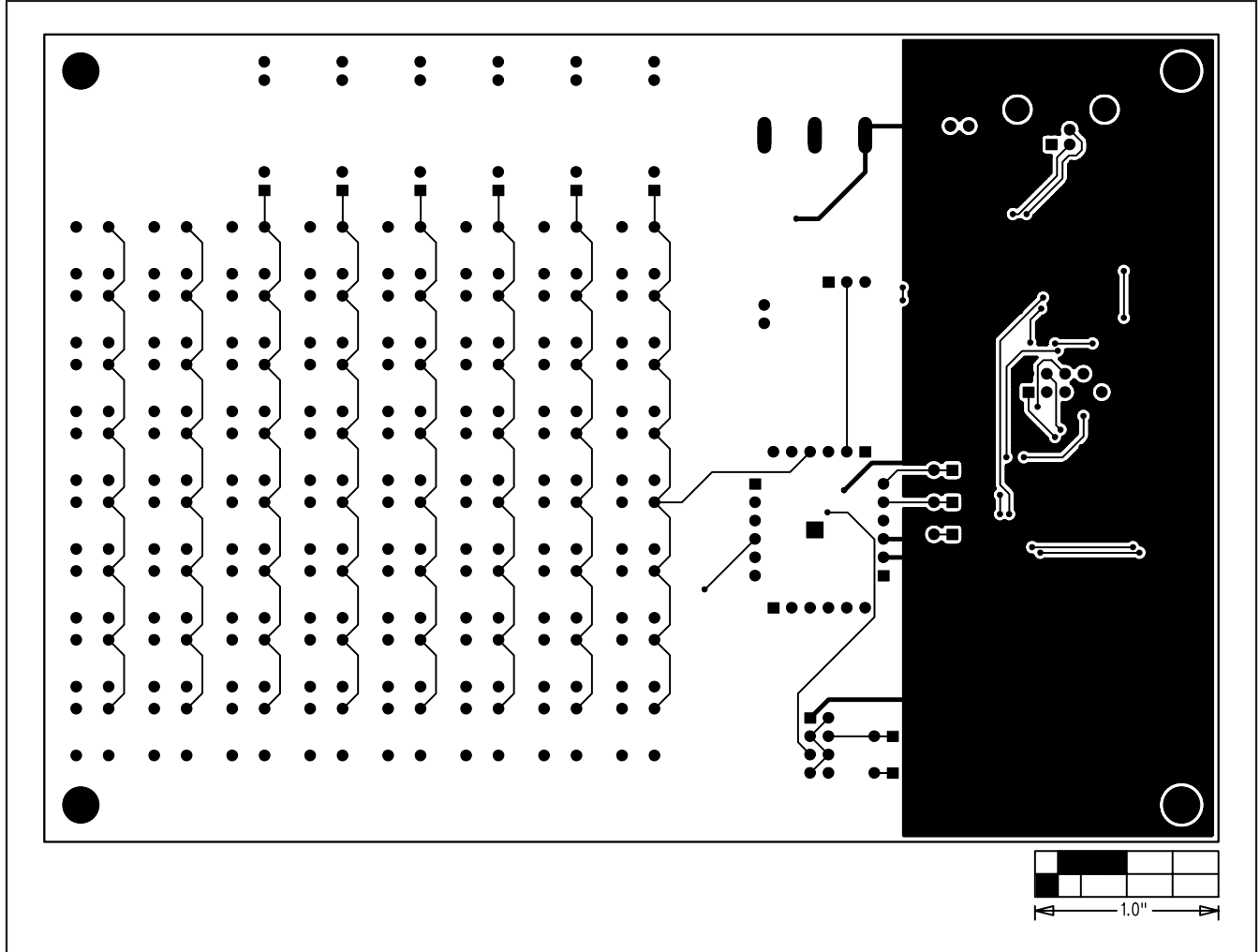

Figure 6. MAX7359 EV Kit PCB Layout—Solder Side

Maxim cannot assume responsibility for use of any circuitry other than circuitry entirely embodied in a Maxim product. No circuit patent licenses are implied. Maxim reserves the right to change the circuitry and specifications without notice at any time.

14 **Maxim Integrated Products, 120 San Gabriel Drive, Sunnyvale, CA 94086 408-737-7600**

© 2007 Maxim Integrated Products

MAXIM is a registered trademark of Maxim Integrated Products, Inc.